

REV.	DESCRIPTION	DATE	DEVISER	APPROVED
A/0	The last word	2009.09.15	Andy Lee	

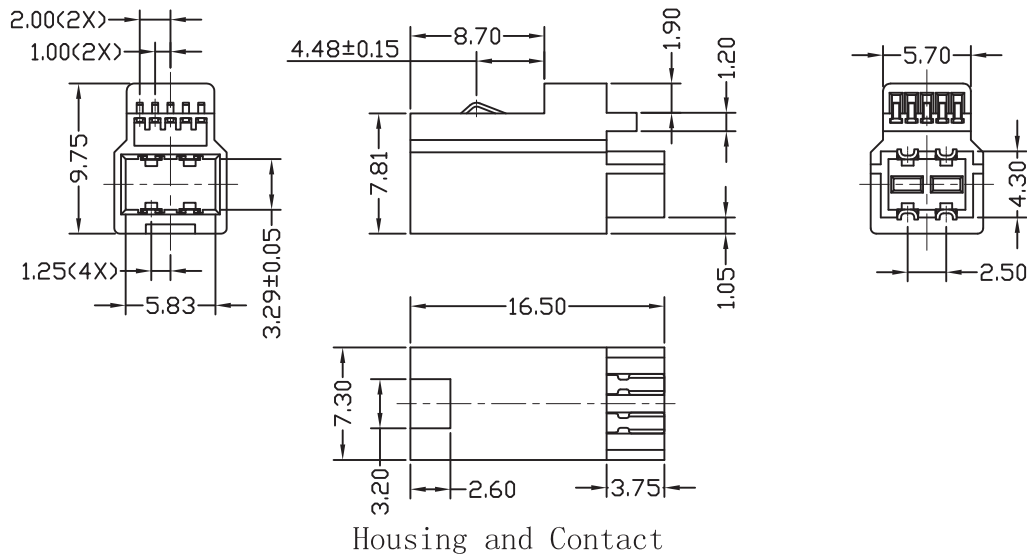
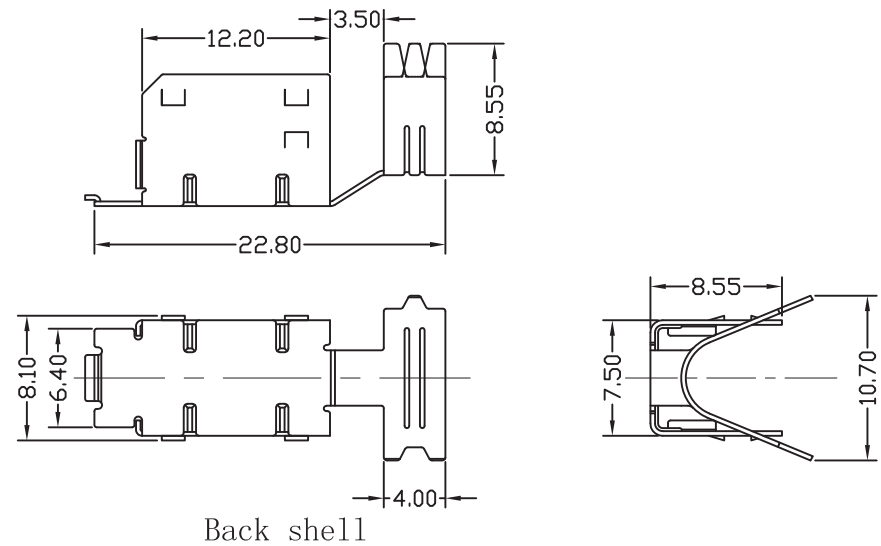
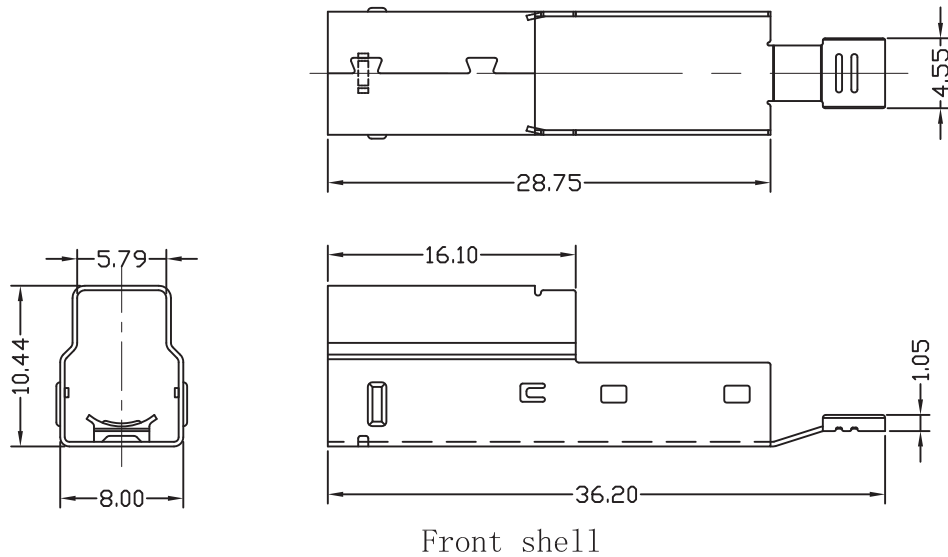

Specification:

- Current Rating:  
1.8 Amp for Pin1&Pin4,  
0.25 Amp for Other Contacts;
- Voltage Rating: 30V;
- Insulation Resistance: 100MΩ Min;
- Contact Resistance:  
30mΩ Max for Pin1&Pin4,  
50mΩ Max for Other Contacts;
- Dielectric Withstanding Voltage: 100V AC (RMS);
- Temperature Rating: -20°C to +85°C;
- Mechanical Characteristics:  
Insertion Force: 35Newtons Maximum;  
Extraction Force: 10Newtons Minimum

5	Back Shell	SPCC T=0.30mm	1	Nickel Plated
4	Front Shell	SPCC T=0.30mm	1	Nickel Plated
3	Contact	C5191 T=0.25mm	5	Gold Plated on area, and Tin Plated on Solder tail.
2	Contact	C2680 T=0.25mm	4	Gold Plated on area, and Tin Plated on Solder tail.
1	Housing	PBT (Blue)	1	UL94 V-0
NO.	Description	Material	Q' TY	Remark

TOLERANCES GENERAL:	
.X	± 0.20
.XX	± 0.10
.XXX	± 0.05
ANGLE	
.X	± 2.0°
.XX	± 1.0°

<b>Wellco T&amp;C Co., Ltd.</b>		<a href="http://www.wellco.com.tw">www.wellco.com.tw</a>	
UNIT:	MM	DRAWN:	Andy Lee
3RD:		CHECKED:	
SCALE:	FIT	APPRD:	
REV:	A/0	EXAMINE:	
TITLE:USB-B 9Pin Plug Solder(3.0 Version)		SHEET:	1
		PART NO:	UB09PSXX0104
CHART NO:		9091501	MATE NO: