

recommended pcb layout
Tolerance=±0.10mm

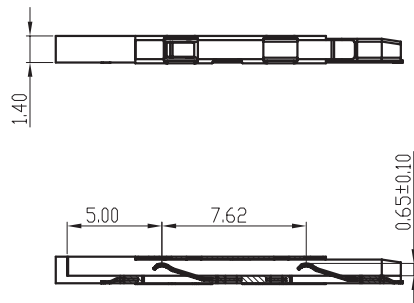

SECTION A-A

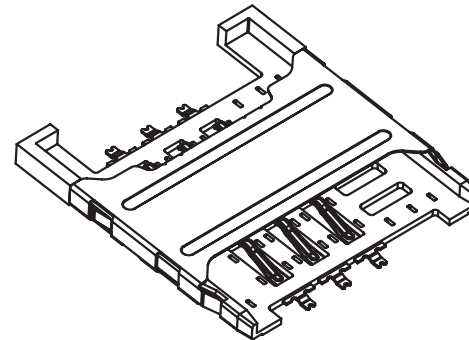

TECHNICAL CHARACTERISTICS

1.General Characteristics

Dimensions: 18.20Lx16.80Wx1.40H mm

Weight: Approx0.40g

Contact principle: friction technology

Operating position: shaft up/down/horizontal

Mounting System: SMT(Post optional)

Durability: 5000cycles min.

2.Mechanical characteristics:

Insulation material: Thermoplastic,UL 94V-0

3.Electrical Characteristics

Number of contacts (Optional): 6pins

contact resistance: 50mΩtypical,100mΩmax

insulation resistance: >1000MΩ/500Vdc

4.Solderability

wave: Not applicable

Vaporphase: 215°C, 30sec. Max

IR reflow: 260°C,10sec.Max

Manual soldering: 360°C,3sec.Max

5.Environmental Characteristics

Operating temperature: -25°C~+70°C

Operating humidity :10%~+95%RH

Storage temperature: -40°C~+85°C

Storage Humidity:10%~95%RH

thermal shock: -40°C~+85°C,5cycles

Damp Heat: 40°C,90%RH,10days.

Salt-Mist: 35°C,5%NaCl,24H

Wellco T&C Co., Ltd.

Smart Card Acceptor

Model No: C701

SIM Card Connector

REVISION:1.0

DATE: AUG. 20. 2009