

REV.	QTY	ECN. NO.	APPD.

- NOTES :
- MATERIAL :  
Housing/Slide : High temperature thermoplastic, UL94-V0. Housing Color : Black  
Slide Color Ivory  
Terminal : Copper Alloy  
Cover : Stainless Steel  
Hook/Spring : Stainless Steel
  - Finish :  
Terminal :  
Underplate : Ni over all.  
Solder tail : Lead Free over Ni plate.  
Contact Area Au over Ni plate.  
Cover :  
Underplate : Ni over all.  
Solder tail : Au over Ni plate.
  - There can't be things to press and hold on the products surface
  - P/N : 879J-N008-00A0

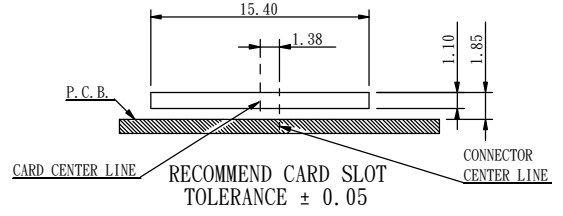
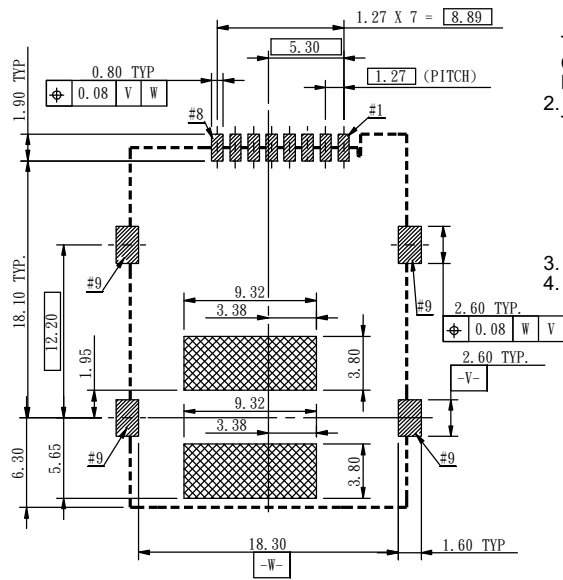
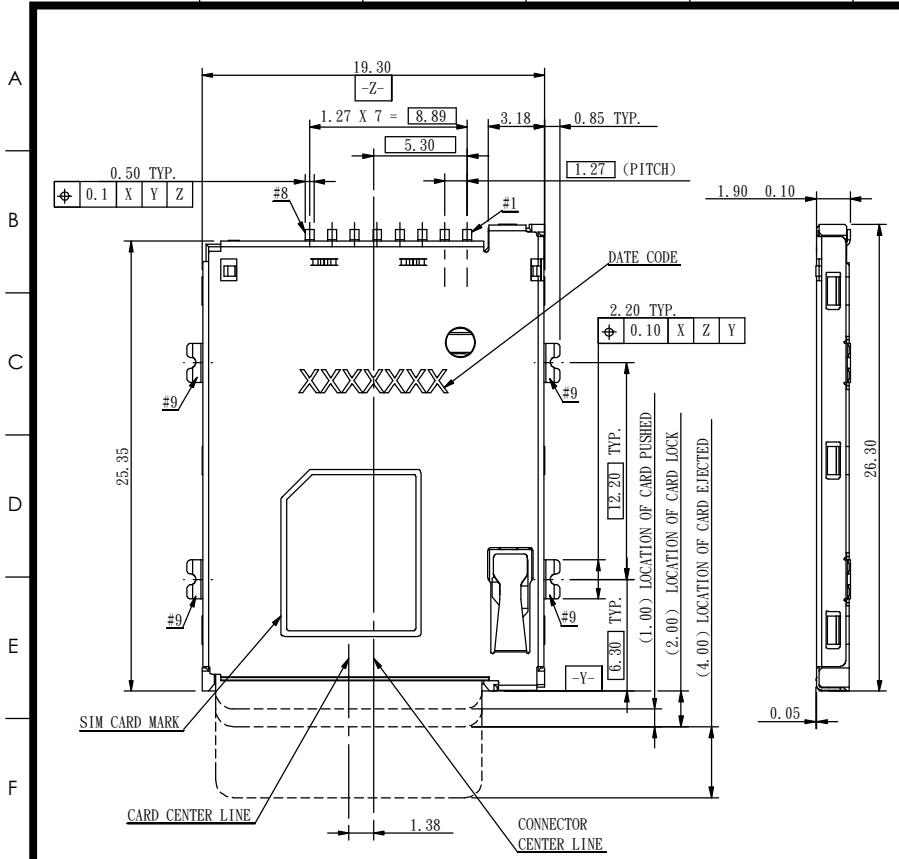
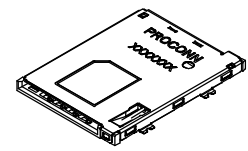

▨ : SOLDER AREA  
▩ : PATTERN PROHIBITED AREA

PIN NO.	NAME
#01	VCC
#02	GND
#03	RST
#04	VPP
#05	CLK
#06	I/O
#07	DAT0
#08	MCMD
#09	GND

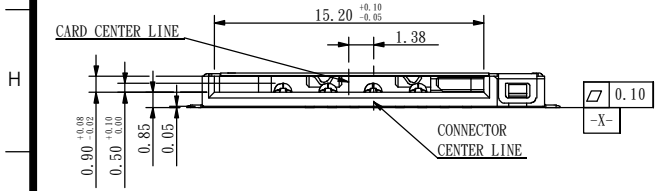

1. WE MEET THE LATEST REQUIREMENT OF PMS-B44-01 AND SONY SS-00259'S MANAGEMENT STANDARD OF AHZARDOUS ENVIRONMENT-RELATED SUBSTANCE  
2. ALL RIGHTS RESERVED PRODUCTS ARE COVERED BY PATENTS AND/OR PATENTS PENDING.

GENERAL TOLERANCE		<b>Wellco T&amp;C Co., Ltd.</b>	
X ± 0.40	X' ± 5°		
.X ± 0.30	.X' ± 2°	TITLE SIM CARD CONNECTOR PUSH TYPE (1.9mm)	
.XX ± 0.20	.XX' ± 1°	PART NO. 879J-N008-00A0	
.XXX ± 0.10	.XXX' ± 0.5°	DWG NO. P303-1000-201	
CUSTOMER DRAWING		SCALE mm	
APPROVAL	CHECKED	SHEET 1 / 2	
DRAWN		REV. Xc	

# 1. Tape packed Status

REV.	Q'TY	ECN. NO.	APPD.

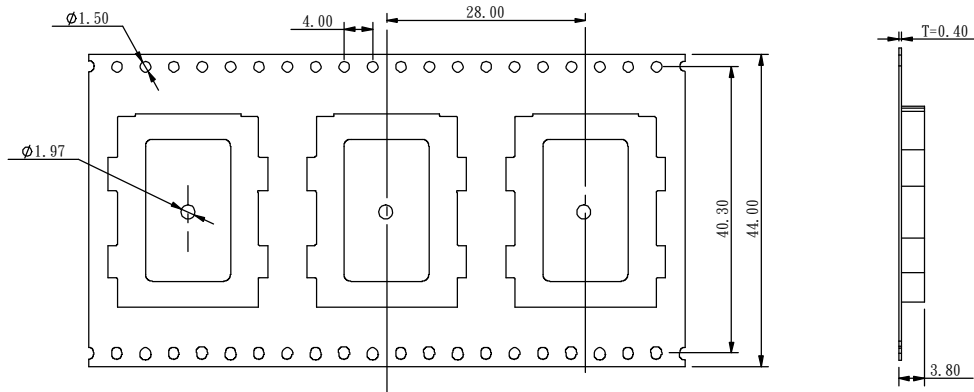

# 3. Carton Containing 5 Reel(See Chart A)

A	Packing Quality	
	Reel	Carton
	500	2500

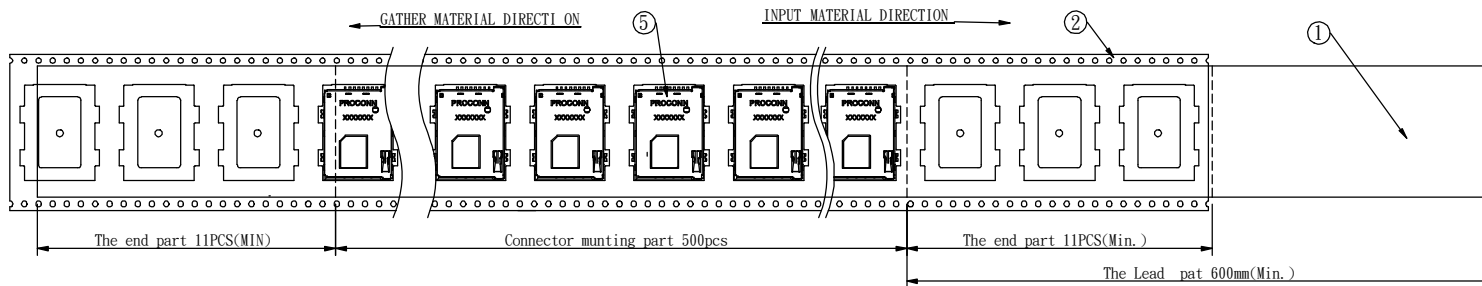
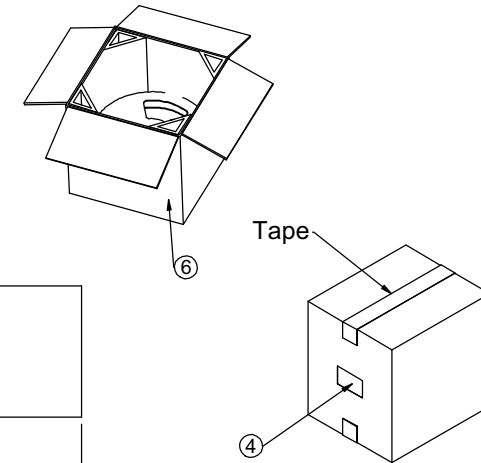

# 2. Reel packed Status

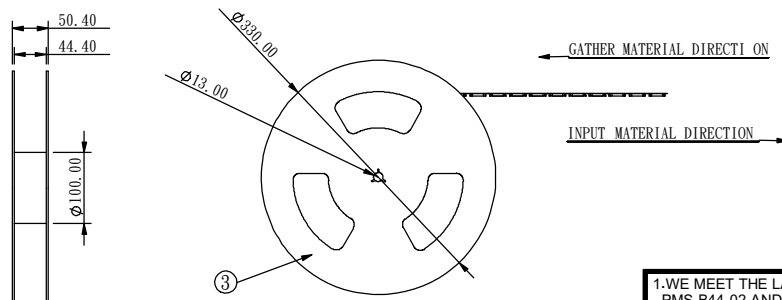

6	Carton	Paper
5	Connector	Other
4	Label	Paper
3	Reel	PS
2	Carrier Tape	PS
1	Cover Tape	PE
Numbers	Name	Material

GENERAL TOLERANCE	
X ± 0.40	X.° ± 5°
.X ± 0.30	.X" ± 2"
.XX ± 0.20	.XX" ± 1"
.XXX ± 0.10	.XXX" ± 0.5"

## Wellco T&C Co., Ltd.

TITLE: SIM CARD CONNECTOR PUSH TYPE (1.9mm)

PART NO. 879J-N008-00A0 DWG. NO. P303-1000-201

CUSTOMER DRAWING

APPROVAL: \_\_\_\_\_ CHECKED: \_\_\_\_\_

SCALE: NONE SHEET: 2 / 2

UNIT: mm

PROJ. [Symbol] REV. Xc

1.WE MEET THE LATEST REQUIREMENT OF PMS-B44-02 AND SONY SS-00259'S MANAGEMENT STANDARD OF AHZARDOUS ENVIRONMENT-RELATED SUBSTANCE.  
2.ALL RIGHTS RESERVED,PRODUCTS ARE COVERED BY PATENTS AND/OR PATENTS PENDING.