

A

B

C

D

E

F

A

B

C

D

E

F

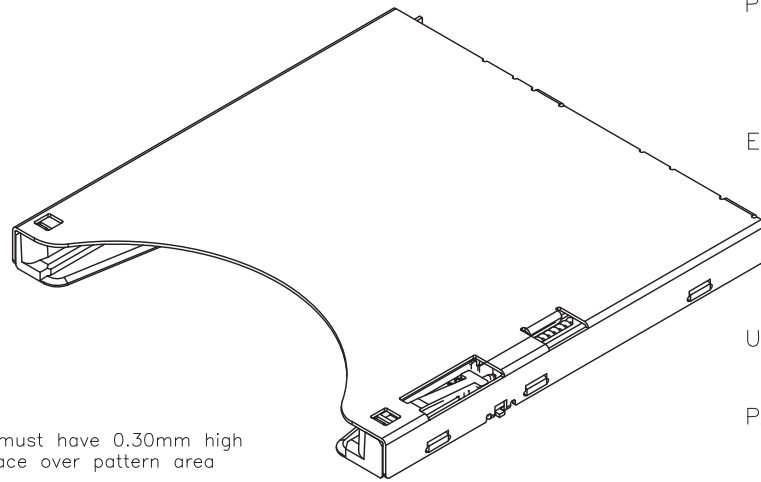
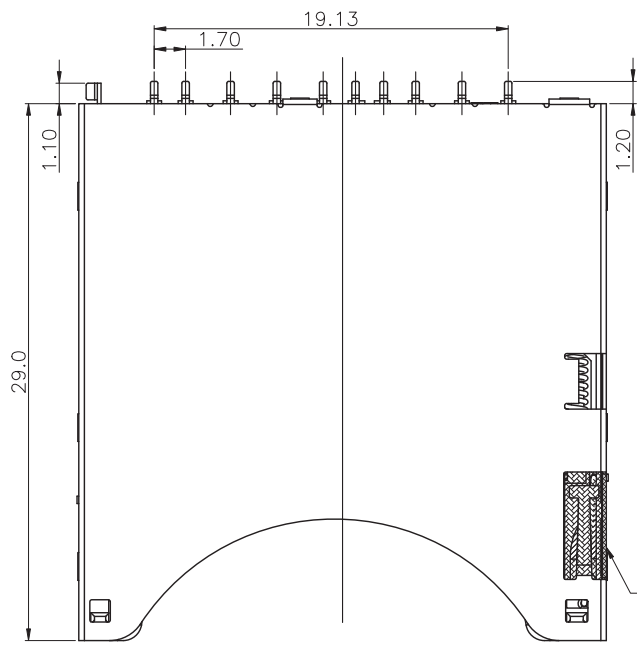

It must have 0.30mm high space over pattern area

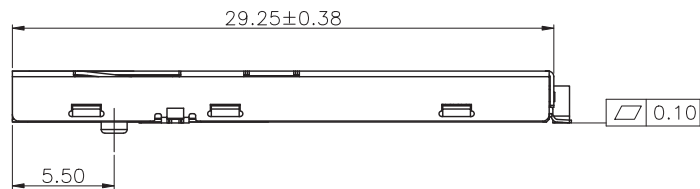
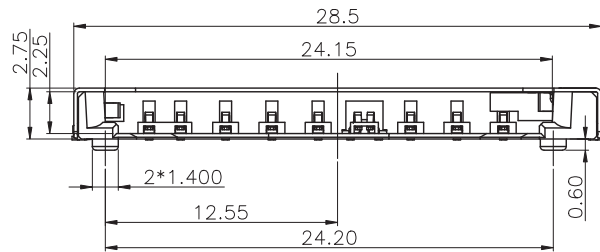

Specification

MATERIAL:

Insulator: High Temperature Thermoplastic,  
Color Black ,UL 94V-0.  
Contact: Copper Alloy  
Shell: Stainless Steel

PLATING:

Contact: Plated 50u" Ni Overall  
Plated Au Selective Contact Area  
Plated 100u" Sn Over Ni On Solder Area  
Shell: Plated 50u" Ni Overall  
Plated Au Selective Solder Area

Electrical:

Current Rating :0.5mA max.  
Contact Resistance:100mΩ max.  
Insulation Resistance:1000MΩ min./500VDC  
Dielectric Withstanding Voltage:500VAC/1 minute  
Operating Temperature:-25°C TO+85°C  
Mating Cycles:6,000 Insertions

Usable Memory Card:

SD&MMC Card

PART NUMBER:

MS-1D31A-KXA-XX0

- S: with mimic card
- 0: without mimic card
- 1: For tray packing
- 3: For tape reel packing
- 1: For Au 1u" Plating
- A: For Au 10u" Plating
- F: For Au 15u" Plating
- U: For Au 30u" Plating

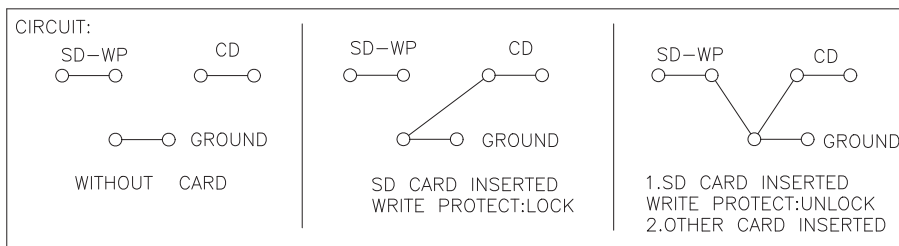

版本 REVISION	設變編號 ECN NO.	設變內容 MODIFICATION	設變者 CHANGE
A		在MS-1D311-KXA-XX0 的基礎上增加機種	王冬賓

# Wellco T&C Co., Ltd.

料號 PART NO	MS-1D31A-KXA-XX0	UNLESS OTHERWISE SPECIFIED. DIMENSION TOLERANCE	品名 PART NAME	SD push-push (Full cover)
設計 DESIGNER	王冬賓	. xxx ± 0.10	圖號 DWG. NO.	
審核 CHECKED	Billy	. xx ± 0.25	單位 UNIT	頁碼 PAGE
核准 APPROVED	Chin	. x ± 0.38	比例 SCALE	1/3
		ANGULAR ± 3°		版次 REVISION
		CUSTOMER COPY		A

Recommend PCB Layout Drawing:  
 (Unit:mm .X ± 0.15 .XX ±0.05 .XXX ± 0.02)

PIN ASSIGNMENT:

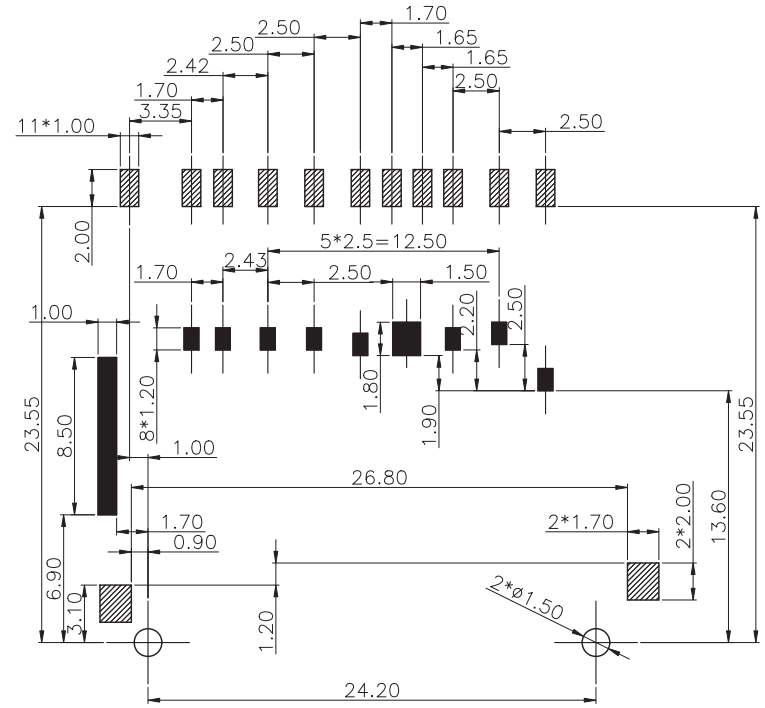
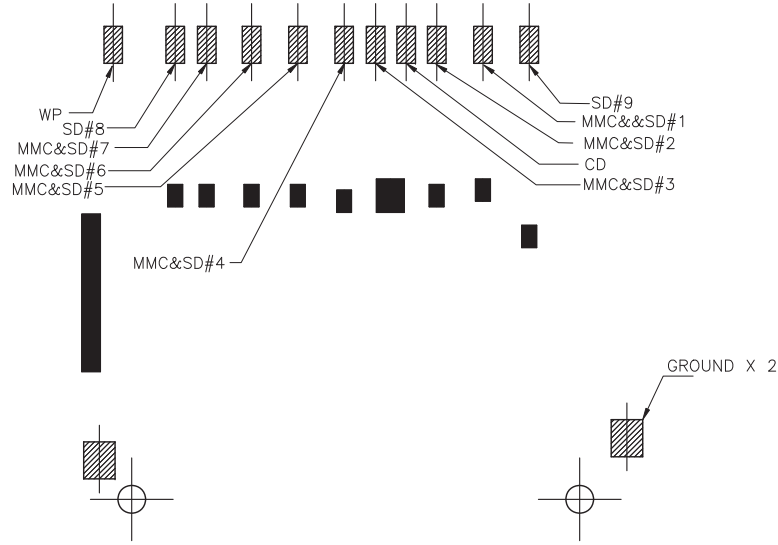

Welding area  
 prohibited layout area

PIN NO.	MEMORY CARD PIN NO.
MMC&SD#1	MMC&SD#1 (CD/DAT3)
MMC&SD#2	MMC&SD#2 (CMD)
MMC&SD#3	MMC&SD#3 (VSS1)
MMC&SD#4	MMC&SD#4 (VDD)
MMC&SD#5	MMC&SD#5 (CLK)
MMC&SD#6	MMC&SD#6 (VSS2)
MMC&SD#7	MMC&SD#7 (DAT0)
SD#8	SD-8 (DAT1)
SD#9	SD-9 (DAT2)

版本 REVISION	設變編號 EGN NO.	設變內容 MODIFICATION	設變者 CHANGE
A		在MS-1D31A-KXA-XX0 的基礎上增加機種	王冬賓

# Wellco T&C Co., Ltd.

料號 PART NO.	MS-1D31A-KXA-XX0	UNLESS OTHERWISE SPECIFIED. DIMENSION TOLERANCE	品名 PART NAME	SD push-push (Full cover)	
設計 DESIGNER	王冬賓	. xxx ± 0.10	圖號 DWG. NO.		
日期 DATE	2008.9.25	. xx ± 0.25	單位 UNIT		頁碼 PAGE 2/3
審核 CHECKED	Billy	. x ± 0.38	比例 SCALE	1:1	版次 REVISION A
核准 APPROVED	Chin	ANGULAR ± 3°			

CUSTOMER COPY

SD CARD INSERT DRAWIGN:

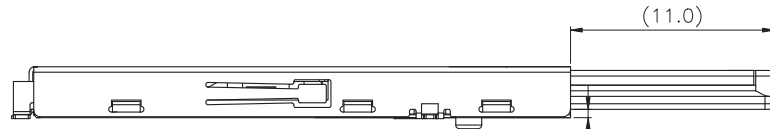

SD CARD -Un Lock

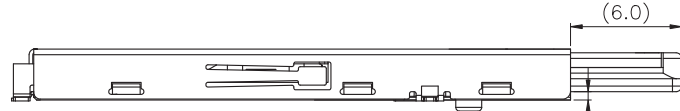

SD CARD -Lock

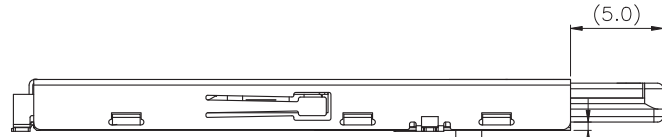

SD CARD -Push

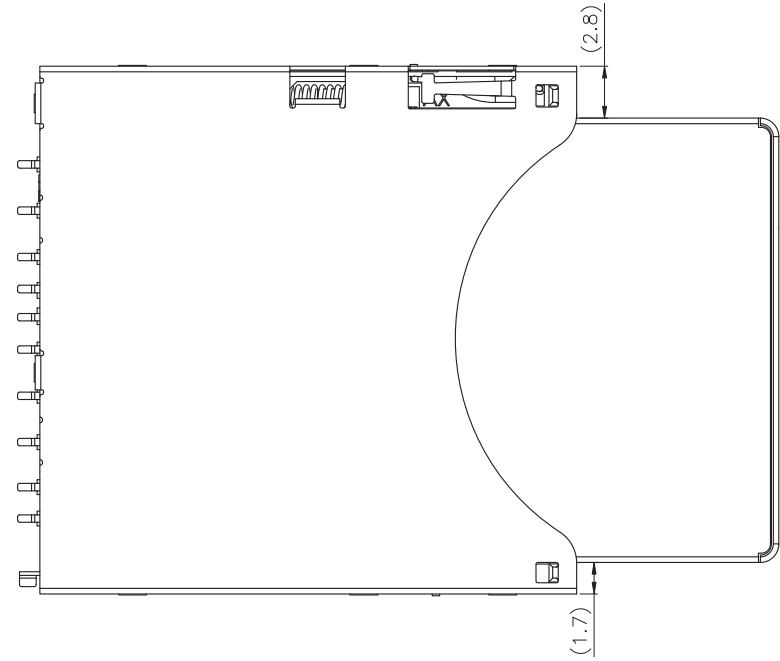

版本 REVISION	設變編號 ECN NO.	設變內容 MODIFICATION	設變者 CHANGE
A		在MS-1D31A-KXA-XX0 的基礎上增加機種	王冬賓

<h1>Wellco T&amp;C Co., Ltd.</h1>			
料號 PART NO	MS-1D31A-KXA-XX0	UNLESS OTHERWISE SPECIFIED. DIMENSION TOLERANCE	品名 PART NAME
設計 DESIGNER	王冬賓	. xxx ± 0.10	SD push-push (Full cover)
審核 CHECKED	Billy	. xx ± 0.25	圖號 DWG. NO.
核准 APPROVED	Chin	. x ± 0.38	單位 UNIT
		ANGULAR ± 3°	頁碼 PAGE
		CUSTOMER COPY	3/3
			比例 SCALE
			1:1
			版次 REVISION
			A